

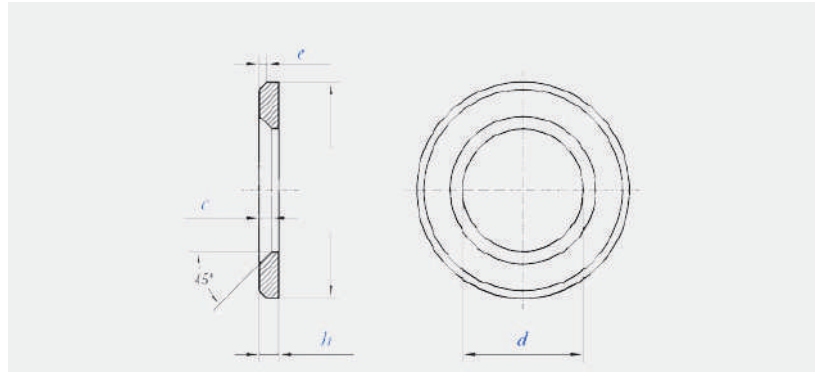

EN 14399 -9 HB washer

螺栓面垫圈HB



Size	d		dc		h		c		e	
	Min	Max	Min	Max	Min	Max	Min	Max	Min	Max
M12	13	13.27	23.48	24	2.7	3.3	1.6	1.9	0.5	1
M16	17	17.27	29.48	30	3.7	4.3	1.6	1.9	0.75	1.5
M20	21	21.33	36.38	37	3.7	4.3	2	2.5	0.75	1.5
M22	23	23.33	38.38	39	3.7	4.3	2	2.5	0.75	1.5
M24	25	25.33	43.38	44	3.7	4.3	2	2.5	0.75	1.5
M27	28	28.52	49	50	4.4	5.6	2.5	3	1	2
M30	31	31.62	54.8	56	4.4	5.6	2.5	3	1	2
M36	37	37.62	64.8	66	5.4	6.6	2.5	3	1.25	2.5